

Residential Pools – In Ground

The following guide is based upon requirements set forth in the Pennsylvania Uniform Construction Code (PAUCC). The information is adapted from the PA UCC, the International Residential Code (2015), and the International Swimming Pool and Spa Code (2015). This guide is intended to provide pertinent and helpful excerpts from the noted sources. **As this is a guide only, contact the authority having jurisdiction for additional requirements or modifications to the following information.**

1. Detailed plans drawn to a suitable scale shall be submitted with the permit application. The plans shall include the following:
 - a. Site/Plot plan showing location of all existing features, property lines, easements, permanent structures, utilities, right of ways, and the location of the proposed pool and any structures (fences, patios, pump/filter equipment pad, etc.).
 - b. Construction details showing the size, spacing, and location of all structural members and reinforcement. Indicate location of steps and/or ladder.
 - c. Pool sections with details.
 - d. Construction details of proposed fence.
 - e. Supplemental information/brochures including specifications on the pool type, installation instructions, pump, filter equipment, lights, alarms, heaters, and all electrical requirements.
2. All equipment, pipe, fittings, and components shall be listed and labeled for their use.
3. All pool equipment and related piping shall be installed, mounted, and supported in accordance with the manufacturers installation instructions.
4. All pool heaters shall be equipped with a readily accessible on-off switch to allow shutting off the heater without adjusting the thermostat setting. Pool heaters fired by natural gas or LPG shall not have continuously burning pilot lights.

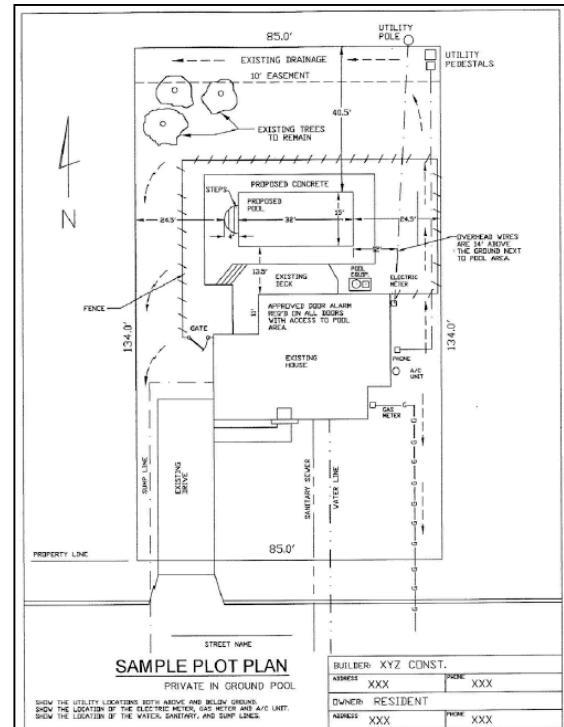

ELECTRICAL REQUIREMENTS

1. Receptacles for pump:
 - a. 20-amp GFCI protected, single twist lock, in weatherproof device box with in-use cover. Locate 6'-10' from inside wall of pool.
 - b. Flexible cord permitted for fixed/stationary equipment. Cord shall not exceed 3-feet in length.
 - c. Disconnecting means shall be readily accessible and within site of the equipment served. Locate 5' from inside wall of the pool.
 - d. All receptacles, panels, or junction boxes shall be mounted on a structural wall, post (typically a pressure treated 4x4 post buried 24" deep), or equal.
 - e. A time switch shall be provided to automatically turn off and on heaters and pump motors.
2. General purpose receptacle
 - a. 125-volt, 15- or 20-amp GFCI protected in weatherproof device box with in-use cover (may not be on pump circuit). Locate 6'-20' from inside wall of pool
 - b. Receptacle shall be mounted on a structural wall, post (typically a pressure treated 4x4 post buried 24" deep), or equal.
3. Wiring
 - a. All wiring to the receptacles shall be buried underground and shall extend 5-feet horizontally from the inside wall of the pool. The minimum burial depth, measured to the top of the conduit, shall be as follows: 6" for rigid metal conduit, 6" for intermediate metal conduit, and 18" for nonmetallic conduit (PVC).
 - b. All conductors must be in conduit that is suitable for the application.
 - c. Conductors inside of conduits shall be insulated: #12 AWG for 20 amp (120V) and rated for wet locations.

4. Bonding

- a. The following parts shall be joined to form an electrically conductive path that will ensure electrical continuity to safely guard against any electrical current that may likely be imposed: pool motor, conductive pool shells, all metallic parts of a pool structure, ladders, slides, underwater lighting (except listed low-voltage lighting with non-metallic shells), metal fittings, electrical equipment, any metal within 5-feet horizontally of the inside walls of the pool, and any metal within 12-feet vertically above the maximum water level of the pool.
- b. #8 AWG bare solid copper wire located 18"-24" from the inside walls of the pool and buried 4"-6" below grade. The wire shall be connected to the pool at four equally spaced locations. Connections shall be made by exothermic welding, listed pressure connectors, or clamps that are labeled as being suitable for the purpose.
- c. The pool water shall be bonded with a minimum conductive surface area of 9 square inches. Bond to #8 AWG solid copper bonding system.

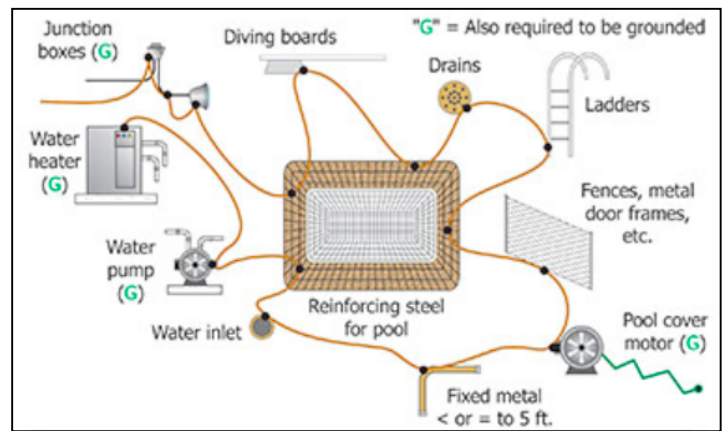

5. Grounding

- a. The following equipment shall be grounded: through wall lighting assemblies and underwater luminaires (except listed low-voltage lighting), all electrical equipment located within 5-feet of the inside wall of the pool, all electrical equipment associated with the recirculating system, junction boxes, transformer and power supply enclosures, GFCI receptacles, and panel boards that are not part of the service equipment and that supply any electrical equipment associated with the pool.
 - b. Minimum #12 AWG insulated solid copper wire.
6. Switching devices shall be located no less than 5-feet horizontally from the inside walls of the pool, except where separated from the pool by a solid fence, wall or other permanent barrier.

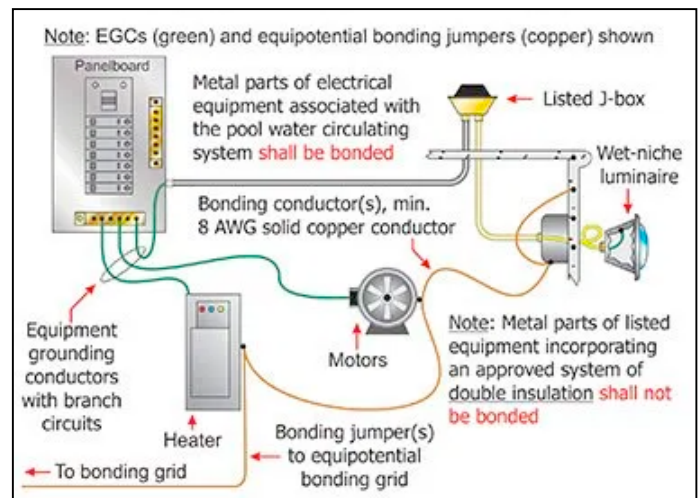

7. One or more means to simultaneously disconnect all ungrounded conductors shall be provided for all equipment other than lighting. Each means shall be readily accessible and within sight from the pool equipment and shall be located no less than 5-feet from the inside walls of the pool.

LIGHTS/LUMINAIRES

1. No-niche luminaires shall comply with the following:
 - a. Luminaires operating at more than 15V shall be GFCI protected. Voltages above 150 are not permitted.
 - b. Shall have a minimum 12-foot long factory installed permanently attached flexible chord. Cord shall have an insulated copper equipment conductor.
 - c. If supplied through a transformer, the transformer shall be listed for the purpose, have an ungrounded secondary, and have a grounded barrier between the primary and secondary windings.
2. Wet-niche luminaires shall comply with the following:
 - a. Luminaires operating at more than 15V shall be GFCI protected. Voltages above 150 are not permitted.
 - b. The top of the lens shall be located a minimum of 18-inches below the normal water level.
 - c. Metal parts of the luminaire and forming shell in contact with the pool water shall be of brass or other approved corrosion-resistant metal.
 - d. Conduit must extend from the forming shell to a junction box and shall be of brass or other approved corrosion-resistant rigid or intermediate metal conduit. Liquid tight flexible non-metallic conduit or rigid nonmetallic conduit may also be used and shall be buried at least 18-inches (measured to the top of the conduit) except where it rises for termination.
 - e. Where nonmetallic conduit is used, a #8 AWG copper wire shall be run between the terminal in the forming shell and the junction box, unless a listed low voltage lighting system is used that does not require grounding. The termination of the #8 AWG bonding jumper in the forming shell must be covered with a listed potting compound to prevent deterioration.

- f. Conductors on load side of the transformer or GFCI shall not occupy conduits, boxes, or enclosures containing other conductors unless the other conductors are also GFCI protected.
 - g. The flexible cord shall be: long enough to reach the decking or other dry location for maintenance (minimum 12-feet), factory installed, permanently attached to the luminaire, complete with grounding conductor not smaller than #16 AWG (connected to a grounding terminal in the supply junction box, transformer enclosure, or other enclosure), and covered or encapsulated at its end with a listed potting compound to prevent entry of water.
3. Dry-niche luminaires shall comply with the following:
- a. Luminaires operating at more than 15V shall be GFCI protected. Voltages above 150 are not permitted.
 - b. Provisions for drainage shall be provided.
 - c. Shall have means to accommodate one equipment grounding conductor for each conduit entry. The equipment grounding conductor shall be #12 AWG (minimum) insulated copper.

CIRCULATION SYSTEM REQUIREMENTS

1. The circulation system consisting of pumps, hoses, tubing, piping, return inlets, suction outlets, filters, and other related equipment shall be located so that such items may not be used as a means of access to the pool.
2. Circulation system equipment shall be sized to provide a turnover of the pool water not less than once every 12 hours.
3. Return fittings shall be provided and arranged to facilitate a uniform circulation of water.
4. A strainer shall be installed on pressure filter systems between the pool and the pump.
5. A backflow preventer shall be installed on the water supply pipe.
6. All outlets, submerged vacuum fittings, and drain covers shall be listed and labeled for suction entrapment avoidance in accordance with APSP 7.

ENTRY AND EXIT REQUIREMENTS

1. A means of entry and exit shall be provided in all shallow areas where the shallowest design water depth exceeds 24-inches and shall be located on the shallow side of the first slope change.
2. A means of entry and exit shall be provided in deep areas where the water depth exceeds 5-feet. Pools over 30' in width at the deep area shall have an entry/exit on both sides of the deep area.
3. Beach and sloping entries, used as a pool entrance, shall not exceed 1-unit vertical in 7-units horizontal.
4. Ladders
 - a. Treads shall have a slip-resistant surface.
 - b. Treads shall have a minimum depth of 2-inches.
 - c. Distance between treads shall be 7" min and 12" max.
 - d. Top tread shall be located 12" max below the top of the deck or coping.
 - e. Clearance between the pool wall and ladder shall be 3" min and 6" max.
 - f. Clear distance between handrails shall be 17" min and 24" max.
5. Stairs
 - a. 10" min tread depth
 - b. 12" max riser height. Additional steps are not required for water depths exceeding 48".

BARRIER REQUIREMENTS

1. Barriers shall be constructed and located to prohibit the barrier, permanent structures, trees, pool equipment, storage boxes, or similar objects from being used for climbing.
 - a. The top of barrier shall be 48" minimum above grade.
 - b. Vertical clearance between grade (grass, mulch, gravel, etc.) and the bottom of the barrier shall not exceed 2-inches.
 - c. Vertical clearance between grade (concrete, asphalt, etc.) and the bottom of the barrier shall not exceed 4-inches.
 - d. Solid barriers (no openings) shall not contain indentations or protrusions except for normal construction tolerances and tooled masonry joints.
 - e. Where the barrier is composed of horizontal and vertical members and the distance between the tops of the horizontal members is less than 45", the horizontal members shall be located on the pool side of the barrier. Spacing between vertical members shall not exceed 1¾-inches in width. Where there are decorative cutouts within vertical members, spacing within the cutouts shall not exceed 1¾-inches in width.
 - f. Where the barrier is composed of horizontal and vertical members and the distance between the tops of the horizontal members is 45" or more, spacing between vertical members shall not exceed 4-inches (spacing

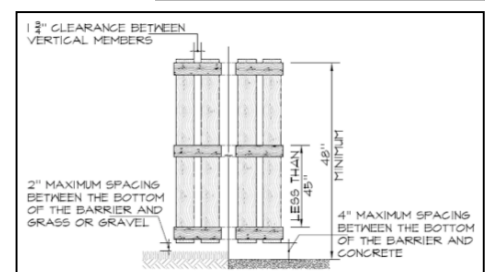
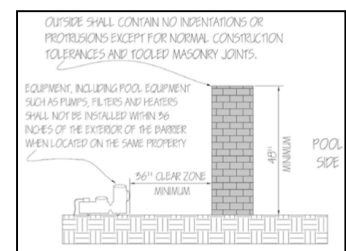

between vertical members shall be less than 4-inches to comply with barrier openings). Where there are decorative cutouts within vertical members, spacing within the cutouts shall not exceed 1¾-inches in width.

- g. Maximum mesh size for chain link fences shall be 1¼-inches square (measured on the diagonal); unless the fence is provided with slats fastened at the top or the bottom; then a standard chain link fence may be used.
- h. Where the barrier is composed of diagonal members, such as lattice fence, the maximum opening formed by the diagonal members shall be no more than 1¾-inches.

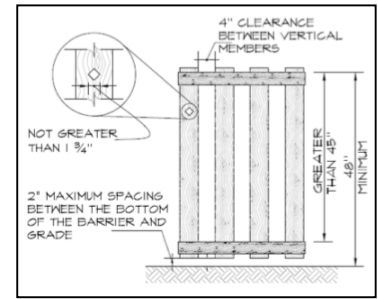

- 2. Openings in the barrier shall not allow passage of a 4-inch sphere.
- 3. Where the wall of the dwelling acts as part of the barrier, operable windows with a sill height of less than 48" above the indoor finish floor and doors shall be equipped with a listed and labeled alarm. The alarm shall activate within 7 seconds and sound continuously for a minimum of 30 seconds immediately after the door and/or its screen is opened and be capable of being heard throughout the house during normal household activities. The alarm shall automatically reset under all conditions. The alarm shall be equipped with a manual means to temporarily deactivate the alarm for a single opening. Such deactivation shall last no more than 15 seconds. The deactivation switch shall be located at least 54" above the threshold of the door. The alarm is an audible warning when the door is opened. The following requirements shall

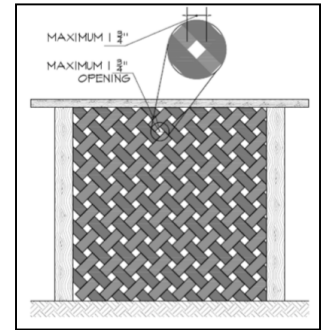

be followed: listed and labeled in accordance with UL 2017, the deactivation switch shall be located at least 54" above the threshold of the door.

GATE REQUIREMENTS

- 1. Pedestrian access gates shall open outward away from the pool and be self-closing and self-latching.
- 2. Gates shall be self-closing and self-latching.
- 3. Gates shall be equipped to accommodate a locking device.
- 4. Gates not intended for pedestrian use shall remain locked when not in use. Double or multiple gates shall have at least one leaf secured in place and the adjacent leaf shall be secured with a self-latching device.
- 5. The release mechanism for gates shall be located 54" above grade or a minimum of 3-inches below the top of the gate and shall be located on the pool side of the gate. The gate and barrier shall have no openings greater than ½-inch within 18" of the release mechanism.

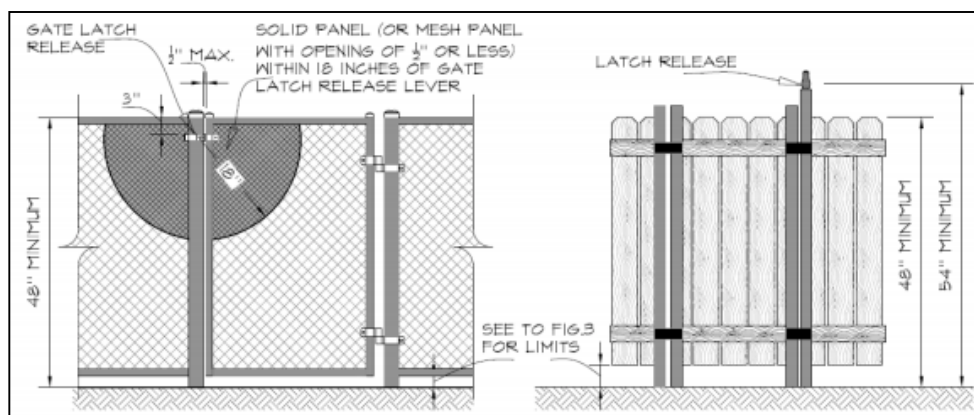
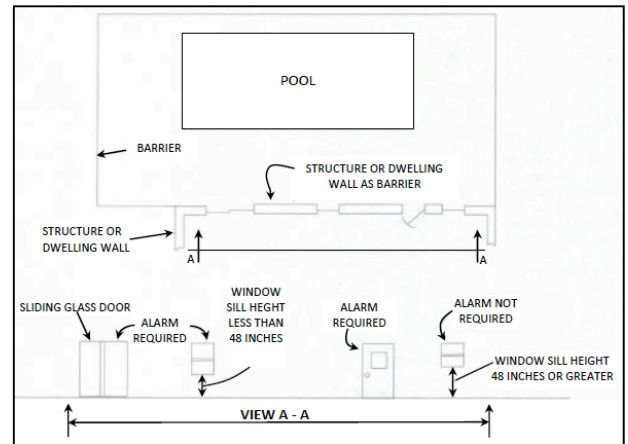

SAFETY FEATURES

- 1. All decks, ramps, stairs, ladders, and walking surfaces surrounding pools must be slip resistant.
- 2. A rope or float assembly shall be installed across the width of the pool not less than 1-foot nor greater than 2-feet from the first slope break of the pool. Rope anchoring devices shall be permanently attached to the pool wall, coping, or deck. Rope ends shall be equipped with a device to allow the rope to be disconnected from the anchoring devices.